



Grown...to meet challenges

INSTRUCTION MANUAL

VITAL

Compact Vibrating Fork Level Switch

Version 2.5

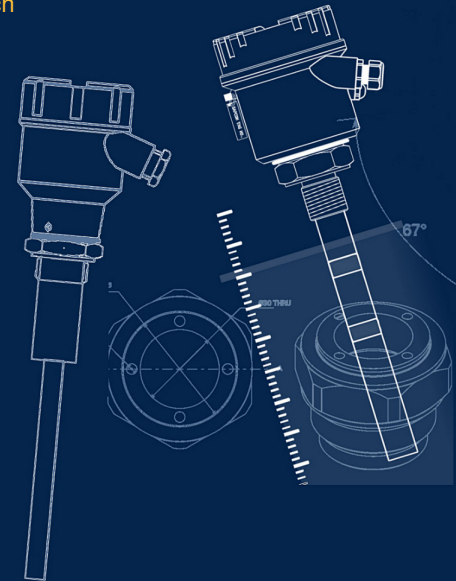
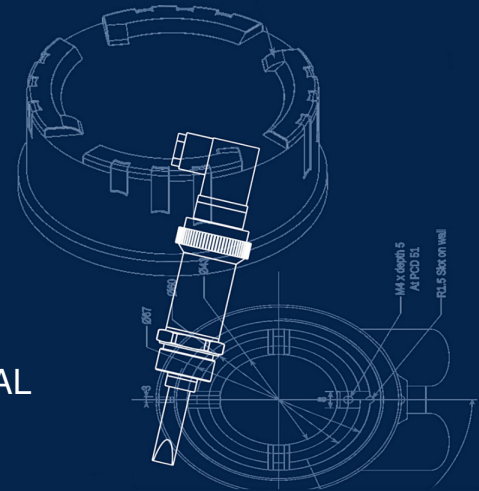

SAPCON INSTRUMENTS PVT. LTD.

30+ Years in Process Control Instrumentation

An ISO 22000 company

www.sapconinstruments.com

Contents

Revision History	4
1 Introduction	5
2 Operating Principle	5
3 Features	5
4 Applications	5
5 Application Specifications	5
6 Electrical Specifications	6
7 Mechanical Specifications	6
8 Installation & Handling Guidelines	7
9 Electrical Connections	7
10 Sensitivity Settings	7
11 Cover Delay	8
12 Uncover Delay	9
13 Failsafe Settings	9
14 Display Indications	9
14.1 STATUS LED	10
15 Troubleshooting & Indications	10
15.1 Output Indications	10
15.2 Troubleshooting	10
16 Maintenance	10
17 For AS-Interface Module	10
17.1 AS-Interface Topology	10
17.2 Electrical Specifications	10
17.3 AS-i Configuration	10
17.4 Electrical Connections	10
17.5 Setting Up AS-Interface	11
17.6 Installation	11
18 Customer Support	11
19 Product Selection Order Code	12
20 AS-Interface Order Code	14

List of Figures

1	Vital Product Image	5
2	Description of Parts	5
3	Correct Side Mounting	7
4	Fork Handling	7
5	Electronics option SPDT Relay and PNP Output(SPN)	7
6	Electronics option DPDT Relay(D)	7
7	DIP Switch	8
8	Sensitivity Switch Position	8
9	Setting Sensitivity Value	8
10	Saving Sensitivity Value	8
11	Cover Delay Switch Position	8
12	Setting Cover Delay	8
13	Saving Cover Delay	8
14	Uncover Delay Switch Position	9
15	Setting Uncover Delay	9
16	Saving Uncover Delay	9
17	Failsafe High	9
18	Failsafe Low	9
19	LED Indication on Top Cover	9
20	AS-Interface	10
21	Electrical Connection	11
22	Connection of Vital via AS-Interface	11
23	Output of AS-Interface	11

List of Tables

1	Application Specifications	5
2	Electrical Specifications	6
3	Mechanical Specifications	6
4	Electrical Specifications	10
5	AS-i Configuration	10

Revision History

Revision	Date	Author(s)	Description
1.0	13 Jan 2014	RND	First Version Editing
1.1	20 Jun 2014	MRK	Applications Revision
1.2	25 Jul 2015	RND	Features Revision
1.3	30 Dec 2015	RND	Specs Revision
1.4	19 Aug 2016	RND	Specs Revision
2.0	08 Jan 2017	BRND	Revised Format
2.1	17 Sep 2017	BRND	Branding Revisions
2.2	26 Feb 2018	BRND	Updated Housing Details
2.3	04 Jul 2018	BRND	Technical Specs Revision
2.4	4 May 2021	RND	Display Section Updated
2.5	16 Aug 2021	RND	Addition of AS-Interface

1

1

- The images shown in this manual may differ from the actual instrument / housing in terms of dimensions, color and design. Please refer to GA drawings for dimensional details.
- Values (of performance) described in this manual were obtained under ideal testing conditions. Hence, they may differ under industrial environment and settings.

General Instructions

- Instrument shouldn't block the material filling inlet.
- Secure the cover of housing tightly. Tighten the cable glands. For side mounting, the cable glands should point downwards.
- For side mounting, provide a baffle to prevent the material from falling on the probe.
- Make all electrical connections as instructed in the manual. DO NOT power on the device before verifying the connections.

1 Introduction

Vital is a vibrating fork level limit switch for free-flowing solids having a maximum granule size ≤ 12 mm. It is suitable for level detection in silos, bins, hoppers, etc. where the process temperature ranges between 0°C to $+150^{\circ}\text{C}$. It has no moving parts and can replace rotating paddle level switch in most applications.



Figure 1: Vital Product Image

2 Operating Principle

A specially shaped tuning fork is kept vibrating using piezo-electric elements. The oscillations of the fork dampen when it comes in contact with the application material. The loss of oscillation amplitude is detected and used for switching the output. The output contacts of the relay are in turn used for annunciation and / or control.

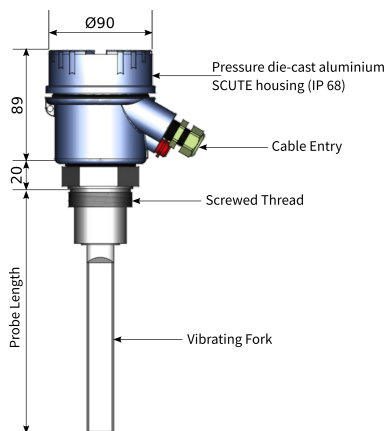

Figure 2: Description of Parts

3 Features

- Low Power Consumption: Less heat, Long life.
- Fast switching minimum of 0.5s available on request with FS option
- Self-diagnosis.
- External LED indication available with WL option
- Independent of material's electrical properties.

- Compact instrument, minimum tines length of 100 mm.
- No moving parts, no wear and tear, maintenance-free.
- IP68 Protection, as per IS 13947.
- Polished tines ideal for hygienic applications with FB option

4 Applications

- Fast Packaging machines for powders, granules
- PET / PVC chips with underwater detection
- Powders, sand & sugar
- Iron ore, sinters & pulverized coal
- Dry sand & Fly-ash
- Food grains
- Cement

5 Application Specifications

Please refer to Table 1 for Application Specifications.

PARAMETER	VALUE
Sensitivity	<ul style="list-style-type: none"> • Dense Media/Build Up - 1 • Lighter Media - 5
Density of media (min)	0.7 gm/cm ³
Grain Size	A maximum of 12mm
Response Time with 'NS' option	<ul style="list-style-type: none"> • Cover Delay : 1-2 second • Uncover Delay : 1-3 seconds
Response Time with 'FS' option	<ul style="list-style-type: none"> • Cover Delay : 1 second • Uncover Delay : 0.8 seconds

Table 1: Application Specifications

6 Electrical Specifications

Please refer to Table 2 for Electrical Specifications.

PARAMETER	VALUE
Input Power Supply	18 - 55V DC and 90 - 265V AC at 50Hz on same terminal
Output	<ul style="list-style-type: none"> Relay DPDT Relay SPDT, PNP
Power Consumption	<ul style="list-style-type: none"> 1.5W (SPDT, PNP) at 24 V 2.2W (DPDT) at 24 V
Switching	Single-point level switching
Switching Indication	Bi-Color LED on the electronics insert <ul style="list-style-type: none"> Green - Normal Red - Alarm External LED between the cable glands(with option WL) <ul style="list-style-type: none"> Blue - Normal Red - Alarm
Fail-safe	Field Selectable <ul style="list-style-type: none"> Open - Fail-safe High (For High Level) Close - Fail-safe Low (For Low Level)
Time Delay Settings	1 - 25 seconds (For both, Covered and Uncovered Delays)
Operating Temperature	<ul style="list-style-type: none"> Ambient Temperature: 0°C to 65°C Process Temperature: 0°C to 100°C with option HT
Relay Rating	6 Amp at 230 VAC

Table 2: Electrical Specifications

7 Mechanical Specifications

Please refer to Table 3 for Mechanical Specifications.

PARAMETER	VALUE
Housing	<ul style="list-style-type: none"> SCUTE: Pressure die-cast aluminium weatherproof (Rating IP-68) FP2C: Cast aluminium, weatherproof & flameproof, powder coated, suitable for Gas Groups IIA, IIB & IIC as per IS-2148
Electrical Connector	PG-13.5, 1/2" BSP DC Glands, 1/2" NPT DC Glands
Mounting	<ul style="list-style-type: none"> Screwed - 1" / 1 1/2" BSP/NTP(M) Flanged - As per your specifications Material - MS (Plated), SS
Sensing Fork	SS 316
Extension Pipe	GI (Galvanized Iron) / SS-304 / SS -316

Table 3: Mechanical Specifications

8 Installation & Handling Guidelines

The fork should be installed in horizontal or vertical position. The following image displays different allowable installation positions. Observe that when installed directly under the material inlet source, a canopy called baffle of appropriate strength and size should be welded right above the fork as shown.

While installing the instrument, please take care of the following points:

- The instrument shouldn't block the material filling inlet.
- Secure the cover of housing tightly. Tighten the cable glands.
- For side-mounting, provide a baffle to prevent the application material from falling on the fork. Please refer to Figure 3.

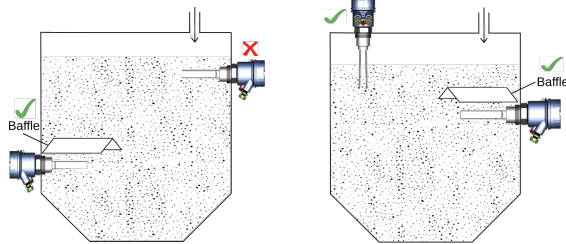

Figure 3: Correct Side Mounting

- When handling forks, do not lift them using their tines. Please see Figure 4.

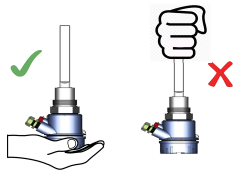

Figure 4: Fork Handling

- The tines should not be bent and neither should their dimensions be altered. Deforming the shape of the tines may interfere with the fork's operating frequency.
- Make all electrical connections as instructed in the manual. Don't power on the device before verifying the connections.
- To prevent the ingress of moisture and water seepage in side mounting position, the cable entries should always point downwards.
- Weatherproofness of enclosure is guaranteed only if the cover is in place glands adequately tightened. Damage due to accidental entry of water can be avoided if the instrument is installed in a rain shade.

- If the ambient temperature is high, the instrument should not be installed to receive direct sunlight. In case such a position of shade is not available, a heat shield should be fitted above the instrument especially if the operating temperature lies between 60°C and 80°C.
- While screwing the instrument, the hexagonal mounting bush should be turned and not the housing.

9 Electrical Connections

Please refer to Figure 5 6 for electrical connections.

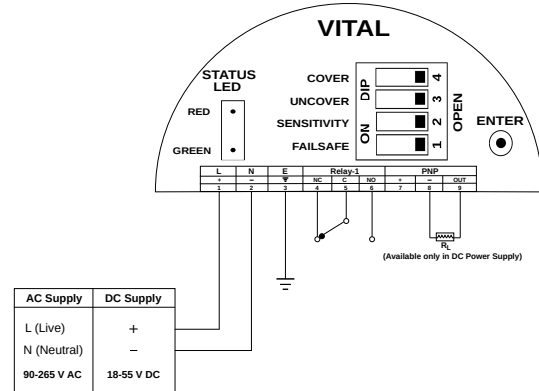

Figure 5: Electronics option SPDT Relay and PNP Output (SPN)

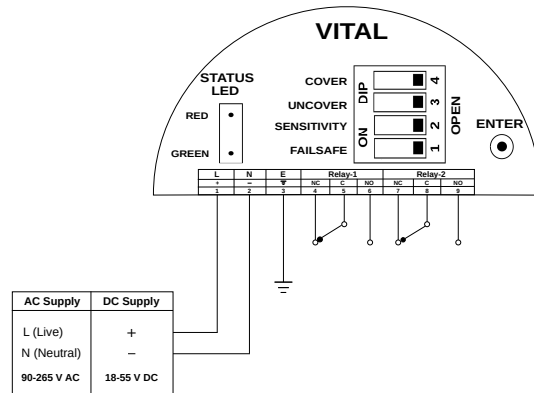

Figure 6: Electronics option DPDT Relay (D)

10 Sensitivity Settings

The sensitivity settings can be set as per the requirement using a DIP switch. The value of sensitivity is directly proportional to the number of blinks. 1 blink is the equivalent to the sensitivity value of 1. Thus, an increase in the number of blinks will make the instrument more sensitive.

Note: Set the value of SENSITIVITY between 1-5.

Follow the below procedure for setting sensitivity

1. Ensure that all DIP switches are in OPEN position as shown in Figure 7. Make sure that STATUS LED is not blinking for Error.

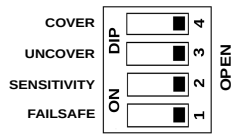

Figure 7: DIP Switch

- Set the SENSITIVITY switch to CLOSE (Opposite of OPEN in a DIP switch) position as shown in Figure 8.

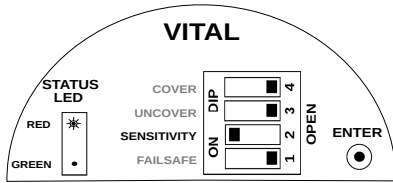

Figure 8: Sensitivity Switch Position

- Press ENTER. The STATUS LED starts blinking. Blink the STATUS LED according to value of sensitivity as shown in Figure 9.
 - 5 blinks indicate highest sensitivity which is required for low density materials.
 - 1 blink refers to lowest value of sensitivity which is required for normal solids.

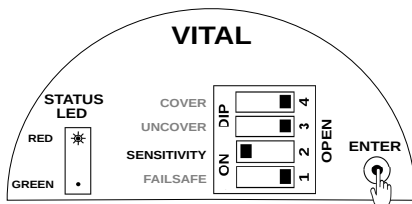

Figure 9: Setting Sensitivity Value

- Sensitivity value is entered, but not saved. To save and test the sensitivity, set the SENSITIVITY switch back to OPEN position as shown in Figure 10.

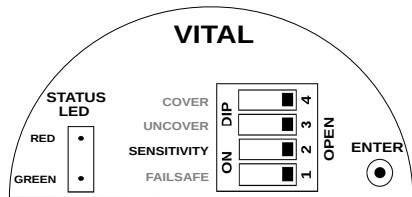

Figure 10: Saving Sensitivity Value

11 Cover Delay

When the application material covers the vibrating fork, the changeover of the output can be delayed by a pre-determined time. This time is called COVER Delay. For a different value of Cover Delay, the number of blinks can be adjusted as per requirement.

Note: Set the value of COVER DELAY between 1-25 secs.

Follow the below procedure for setting Cover Delay

- Ensure that all DIP switches are in OPEN position as shown in Figure 7. Make sure that STATUS LED is not blinking for Error.
- Set the COVER switch to CLOSE (Opposite of OPEN in a DIP switch) position as shown in Figure 11.

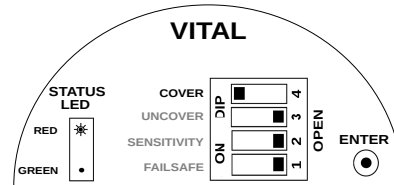

Figure 11: Cover Delay Switch Position

- Press ENTER. The STATUS LED starts blinking. Blink the STATUS LED according to value of cover delay as shown in Figure 12.

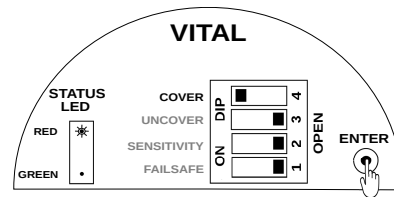

Figure 12: Setting Cover Delay

- Delay is entered, but not saved. To save and test the Cover Delay, set the COVER switch back to OPEN position as shown in Figure 13.

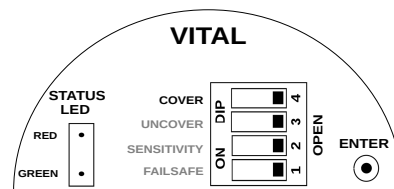

Figure 13: Saving Cover Delay

- To test, dip Vital into the application material until the switching point is reached.
- The STATUS LED will start blinking RED if the switch point is reached. It will blink for the number of seconds for which the cover delay is set. 1 blink is equal to 1 second during switching. A maximum of 25 seconds can be set.

12 Uncover Delay

When the application material uncovers Vital's fork tines, the changeover of the output can be delayed by a pre-determined time. This time is called UNCOVER Delay. For a different value of Uncover Delay, the number of blinks can be adjusted as per requirement.

Note: Set the value of UNCOVER DELAY between 1-25 secs.

Follow the below procedure for setting Uncover Delay

1. Ensure that all DIP switches are in OPEN position as shown in Figure 7. Make sure that STATUS LED is not blinking for Error.
2. Set the UNCOVER switch to CLOSE (Opposite of OPEN in a DIP switch) position as shown in Figure 14.

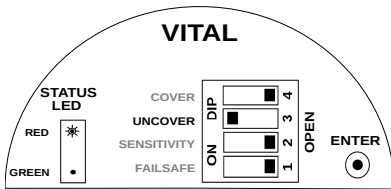

Figure 14: Uncover Delay Switch Position

3. Press ENTER. The STATUS LED starts blinking. Blink the STATUS LED according to value of uncover delay as shown in Figure 15.

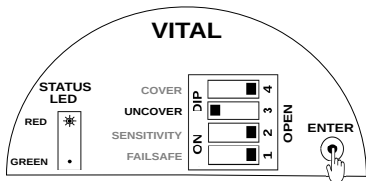

Figure 15: Setting Uncover Delay

4. Uncover Delay is entered, but not saved. To save and test the Uncover Delay, set the UNCOVER switch back to OPEN position as shown in figure 16.

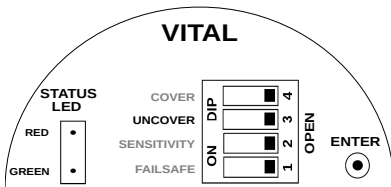

Figure 16: Saving Uncover Delay

5. To test, dip Vital into the application material until the switching point is achieved.

6. The STATUS LED will start blinking GREEN if the switch point is achieved. It will blink for the number of seconds for which the Uncover Delay is set.

13 Failsafe Settings

In a condition of device failure, known errors and input power failure the outputs of the device resemble the ALARM condition. This is meant to prevent overflow or dry run conditions in case of failures.

Prevent Overflow - High Level Switch Failsafe High (default) is set by moving the Failsafe switch to OPEN position.

1. When not in contact with the material, LED turns GREEN.
2. When in contact with the material, LED turns RED.

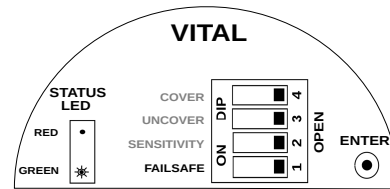

Figure 17: Failsafe High

Prevent Dry run - Low Level Switch Failsafe Low is set by moving the Failsafe switch to CLOSE position

1. When in contact with the material, LED turns GREEN.
2. When not in contact with the material, LED turns RED.

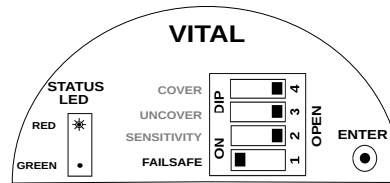

Figure 18: Failsafe Low

14 Display Indications

As seen in Fig.19, Vital has STATUS LEDs to show output indication.

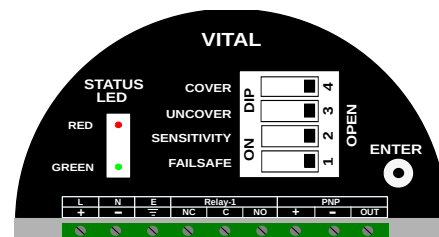

Figure 19: LED Indication on Top Cover

14.1 STATUS LED

A separate STATUS LED section indicate switching status for normal and alarm conditions.

- **RED** LED: Alarm Condition
- **GREEN** LED: Normal Condition

Continuous blinking of Red or Green LED could indicate an error, refer to Troubleshooting & Indications.

15 Troubleshooting & Indications

15.1 Output Indications

Green LED Glows When:

- Fork is Uncovered and Failsafe is High
- Fork is Covered and Failsafe is Low

Red LED Glows When:

- Fork is Covered and Failsafe is High
- Fork is Uncovered and Failsafe is Low

15.2 Troubleshooting

- The instrument is working but there may be solid particles in the application material that may be clogging the fork tines. Make sure particle size is 12 mm.
- Heavy build-up of application material can dampen the fork oscillations. In this case, the fork requires to be cleaned. To avoid build up change sensitivity value to 1.
- If the vibrating fork is not sensing application media, consider changing the sensitivity.
- If instrument is not powering on (No LED is glowing). Check input supply voltage. It should be in the range mentioned in Electrical Specifications
- **Connectivity between Vibrating fork and Electronics is broken**
 - In failsafe 'High' mode, instrument will switch to ALARM
 - In failsafe 'Low' mode, instrument will switch to NORMAL

16 Maintenance

The electronics of Vital instrument needs no maintenance. When cleaning and checking the vessel, free the tuning fork from deposits. If the material has tendency to form a hard sticky deposit, the instrument must be checked more often. Make sure that the cable ducts and the lid are tightly sealed so that no moisture seeps into the instrument.

17 For AS-Interface Module

17.1 AS-Interface Topology

AS-Interface by design is a loop-powered digital bus. The 2-wire unshielded lines carry power as well as data on them. The single cabling system connects I/O devices with automation systems as shown in Figure 20. ASi-3 is based

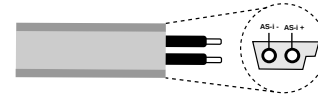

Figure 20: AS-Interface

on a master-slave system where single master can transfer input and output data with up to 62 slaves.

17.2 Electrical Specifications

Please refer to Table 4 for Electrical Specifications.

PARAMETER	VALUE
Input Power Supply	24-30V DC
Electrical Connector	PG-13.5, 1/2" BSP DC Glands, 1/2" NPT DC Glands
Current Consumption	60mA @24V DC
Fail-safe Settings	User selectable (Field selectable through toggle switch) <ul style="list-style-type: none"> • Open: Fail-safe High • Close: Fail-safe Low

Table 4: Electrical Specifications

17.3 AS-i Configuration

Please refer to Table 5 for AS-Interface Configuration.

PARAMETER	VALUE
AS-i Version	3
Max. Slaves	62 Slave
Max. Cable Length	100m
Communication Method	Master/Slave with cyclic polling
Communication Speed	167 kbits/sec
Max. Data Size	8 bits

Table 5: AS-i Configuration

17.4 Electrical Connections

Please refer to the Figure 21 for electrical connections of AS-Interface Module.

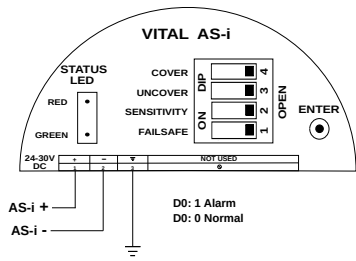

Figure 21: Electrical Connection

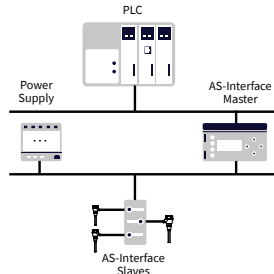

Figure 22: Connection of Vital via AS-Interface

17.5 Setting Up AS-Interface

Note: ASi-4 and ASi-5 are later versions of the AS-i protocol. However, ASi-3 version is the most prevalent. ASi-4 & ASi-5 are backwards compatible with ASi-3.

AS-Interface can set up easily using a PLC with AS-Interface bus input. Follow these steps for setting up the AS-Interface bus with Vital:

- **Set Unique Bus ID:** Assign and set a unique bus identification for the slave device. This can be done by using an AS-I master device. Each device should have a unique bus identification. For setting the ID, there needs to be single device connected to the AS-Interface, other slaves need to be disconnected from the bus.
- **Check Configuration:** Use the failsafe switch to toggle the output and observe the change in the D0 bit for the assigned address. The output change can be observed via a PLC or a SCADA system connected to the PLC.

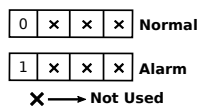

Figure 23: Output of AS-Interface

17.6 Installation

Proceed to Section [Installation Guidelines](#) for installing the product in an application tank and then refer to given Figure 21 for connecting Vital AS-i.

18 Customer Support

Thank you for going through the instructions given in this manual. To further ease the process of installation and use, we have developed special demo videos which are hosted on YouTube.

Sapcon's YouTube channel, SAPCON INSTRUMENTS, lists all these videos: <https://goo.gl/dnxfcz>

Should you require further information regarding installation, use or working of the instrument, please don't hesitate to contact us. Kindly provide the following information at the time of contacting:

- Instrument Model and Serial Number
- Purchase Order Number and Date of Purchase
- Description of the query
- Your contact details

In an attempt to serve you better, we are open seven days a week (9:30am to 7:30pm). We are available at:

- www.sapconinstruments.com
- sales@sapcon.in
- +91-731-4757575

19 Product Selection Order Code

Product	
VITAL : VITAL_T - Vibrating Fork	
Type	I : Integral (sensor in the same unit)
Housing	SCUTE : Pressure Die Cast Aluminium, weatherproof, powder-coated, IP68 FP2C : Cast Aluminium, weather & flameproof, IEC 60079-1 Ex 'd', powder-coated suitable for gas group IIC, IP66
Indication (Optional)	WL : With LED (Only with "SCUTE")
Probe Housing Cable Entry	PCPG13 : Threaded, PG 13.5 cable gland, Polyamide PCB5D : Threaded, G 1/2" (BSP), DC gland, Brass (Ni plated) PCN5D : Threaded, 1/2" NPT, DC gland, Brass (Ni plated)
Output	D : DPDT Relay (rated at 6A, 230V AC for non inductive load) SPN : One SPDT Relay (rated at 6A, 230V AC for non inductive load) and one PNP output (only for 18 To 35V DC supply voltage)
Power Supply	U : Universal (18 to 55V DC and 90 to 265V AC, 50Hz) on the same terminals
Switching (Depends on "Vibrating Fork")	FS : Time Delay (Adjustable from 0.5 to 20 seconds for probe covered or uncovered) (Only with "VF105S", "VF130") NS : Normal Time Delay (Adjustable from 2 to 20 seconds for probe covered or uncovered)
Mounting	MB10S6 : Threaded, G 1" (BSP), SS 316 (Only with "VF110") MN10S6 : Threaded, NPT 1", SS 316 (Only with "VF110") MB15MS : Threaded, G 1 1/2" (BSP), MS Plated MB15S4 : Threaded, G 1 1/2" (BSP), SS 304 MB15S6 : Threaded, G 1 1/2" (BSP), SS 316 MN15MS : Threaded, NPT 1 1/2", MS Plated MN15S4 : Threaded, NPT 1", SS 304 MN15S6 : Threaded, NPT 1 1/2", SS 316 FA20MS : 2" ANSI/ASME B16.5 150 Lbs Flange, MS Plated FA20S4 : 2" ANSI/ASME B16.5 150 Lbs Flange, SS 304 FA20S6 : 2" ANSI/ASME B16.5 150 Lbs Flange, SS 316 FA25MS : 2 1/2" ANSI/ASME B16.5 150 Lbs Flange, MS Plated FA25S4 : 2 1/2" ANSI/ASME B16.5 150 Lbs Flange, SS 304 FA25S6 : 2 1/2" ANSI/ASME B16.5 150 Lbs Flange, SS 316 FA30MS : 3" ANSI/ASME B16.5 150 Lbs Flange, MS Plated (VF110) FA30S4 : 3" ANSI/ASME B16.5 150 Lbs Flange, SS 304 FA30S6 : 3" ANSI/ASME B16.5 150 Lbs Flange, SS 316 F20MS : 10 mm thick Flange conforming to 2" ANSI/ASME B16.5 Flange, MS Plated F20S4 : 10 mm thick Flange conforming to 2" ANSI/ASME B16.5 Flange, SS 304 F20S6 : 10 mm thick Flange conforming to 2" ANSI/ASME B16.5 Flange, SS 316 F25MS : 10 mm thick Flange conforming to 2 1/2" ANSI/ASME B16.5 Flange, MS Plated

Mounting	
F25S4 : 10 mm thick Flange conforming to 2½" ANSI/ASME B16.5 Flange, SS 304	
F25S6 : 10 mm thick Flange conforming to 2½" ANSI/ASME B16.5 Flange, SS 316	
F30MS : 10 mm thick Flange conforming to 3" ANSI/ASME B16.5 Flange, MS Plated (VF110)	
F30S4 : 10 mm thick Flange conforming to 3" ANSI/ASME B16.5 Flange, SS 304	
F30S6 : 10 mm thick Flange conforming to 3" ANSI/ASME B16.5 Flange, SS 316	
Vibrating Fork (Depends on "Probe Length")	
VF105S : 105 mm, Tines 100 mm, SS 316 (Only with "1.3H")	
VF110 : Fluido Fork, 110 mm, Tines 100 mm, SS 316 (Powder Application) (Only with "1.3H", "1.75H" & "2H30H")	
VF130 : 130 mm, Tines 100 mm, SS 316 (Only with "1.45H" & "2H30H")	
VF130S : 130 mm, Tines 125 mm, SS 316 (Only with "1.55H")	
VF185 : 185 mm, Tines 155 mm, SS 316 (Only with "2H", "2H30H" & "2.5H30H")	
Finish	
HB : Standard	
FB : Fully Buffed	
Extension Material (Depends on "Probe Length", Only with "2H30H", "2.5H30H")	
EGL : GI (Galvanized Iron)	
ES4 : SS 304	
ES6 : SS 316	
Operating Temperature	
10T : Upto 100°C	
20T : Upto 200°C	
Standoff Material (Depends on "Operating Temperature", Only with "20T")	
STGI : GI (Galvanized Iron)	
STS4 : SS 304	
STS6 : SS 316	
Probe Length (Depends on "Vibrating Fork")	
1.3H : 130 mm (Only with "VF105S" & "VF110")	
1.45H : 145 mm (Only with "VF130")	
1.55H : 155 mm (Only with "VF130S")	
1.75H : 175 mm (Only with "VF110")	
2H30H : 200 to 3000 mm (Only with "VF110", "VF130" & "VF185: Flange version")	
2H : 200 mm (Only with "VF185")	
2.5H30H : 250 to 3000 mm (Only with "185" & "Screwed Mounting")	

Example - VITAL-I-SCUTE-PCPG13-D-U-NS-MB15S4-VF185-HB-10T-2H

● Not Applicable

20 AS-Interface Order Code

Product

VITAL : Vibrating Fork Type Level Limit Switch for Free-flowing Solids, Granules and Powders

Type

I : Integral (sensor in the same unit)

Housing

SCUTE : Pressure Die Cast Aluminium, weatherproof, powder-coated, IP68

FP2C : Cast Aluminium, weather & flameproof, IEC 60079-1 Ex 'd', powder-coated suitable for gas group IIC, IP66

Indication (Optional)

WL : With LED (Only with "SCUTE")

Probe Housing Cable Entry

PCPG13 : Threaded, PG 13.5 cable gland, Polyamide

PCB5D : Threaded, G 1/2" (BSP), DC gland, Brass (Ni plated)

PCN5D : Threaded, 1/2" NPT, DC gland, Brass (Ni plated)

Output

ASI-3 : ASI-3, Actuator Sensor Interface, 4-bit bus

Switching (Depends on "Vibrating Fork")

FS : Time Delay (Adjustable from 0.5 to 20 seconds for probe covered or uncovered) (Only with "VF105S", "VF130")

NS : Normal Time Delay (Adjustable from 2 to 20 seconds for probe covered or uncovered)

Mounting

MB10S6 : Threaded, G 1" (BSP), SS 316 (Only with "VF110")

MN10S6 : Threaded, NPT 1", SS 316 (Only with "VF110")

MB15MS : Threaded, G 1 1/2" (BSP), MS Plated

MB15S4 : Threaded, G 1 1/2" (BSP), SS 304

MB15S6 : Threaded, G 1 1/2" (BSP), SS 316

MN15MS : Threaded, NPT 1 1/2", MS Plated

MN15S4 : Threaded, NPT 1", SS 304

MN15S6 : Threaded, NPT 1 1/2", SS 316

FA20MS : 2" ANSI/ASME B16.5 150 Lbs Flange, MS Plated

FA20S4 : 2" ANSI/ASME B16.5 150 Lbs Flange, SS 304

FA20S6 : 2" ANSI/ASME B16.5 150 Lbs Flange, SS 316

FA25MS : 2 1/2" ANSI/ASME B16.5 150 Lbs Flange, MS Plated

FA25S4 : 2 1/2" ANSI/ASME B16.5 150 Lbs Flange, SS 304

FA25S6 : 2 1/2" ANSI/ASME B16.5 150 Lbs Flange, SS 316

FA30MS : 3" ANSI/ASME B16.5 150 Lbs Flange, MS Plated (VF110)

FA30S4 : 3" ANSI/ASME B16.5 150 Lbs Flange, SS 304

FA30S6 : 3" ANSI/ASME B16.5 150 Lbs Flange, SS 316

F20MS : 10 mm thick Flange conforming to 2" ANSI/ASME B16.5 Flange, MS Plated

F20S4 : 10 mm thick Flange conforming to 2" ANSI/ASME B16.5 Flange, SS 304

F20S6 : 10 mm thick Flange conforming to 2" ANSI/ASME B16.5 Flange, SS 316

F25MS : 10 mm thick Flange conforming to 2 1/2" ANSI/ASME B16.5 Flange, MS Plated

F25S4 : 10 mm thick Flange conforming to 2 1/2" ANSI/ASME B16.5 Flange, SS 304

F25S6 : 10 mm thick Flange conforming to 2 1/2" ANSI/ASME B16.5 Flange, SS 316

Mounting	<ul style="list-style-type: none"> F30MS : 10 mm thick Flange conforming to 3" ANSI/ASME B16.5 Flange, MS Plated (VF110) F30S4 : 10 mm thick Flange conforming to 3" ANSI/ASME B16.5 Flange, SS 304 F30S6 : 10 mm thick Flange conforming to 3" ANSI/ASME B16.5 Flange, SS 316
Vibrating Fork (Depends on "Probe Length")	<ul style="list-style-type: none"> VF105S : 105 mm, Tines 100 mm, SS 316 (Only with "1.3H") VF110 : Fluido Fork, 110 mm, Tines 100 mm, SS 316 (Powder Application) (Only with "1.3H", "1.75H" & "2H30H") VF130 : 130 mm, Tines 100 mm, SS 316 (Only with "1.45H" & "2H30H") VF130S : 130 mm, Tines 125 mm, SS 316 (Only with "1.55H") VF185 : 185 mm, Tines 155 mm, SS 316 (Only with "2H", "2H30H" & "2.5H30H")
Finish	<ul style="list-style-type: none"> HB : Standard FB : Fully Buffered
Extension Material (Depends on "Probe Length", Only with "2H30H", "2.5H30H")	<ul style="list-style-type: none"> EGL : GI (Galvanized Iron) ES4 : SS 304 ES6 : SS 316
Operating Temperature	<ul style="list-style-type: none"> 10T : Upto 100°C 20T : Upto 200°C
Standoff Material (Depends on "Operating Temperature", Only with "20T")	<ul style="list-style-type: none"> STGI : GI (Galvanized Iron) STS4 : SS 304 STS6 : SS 316
Probe Length (Depends on "Vibrating Fork")	<ul style="list-style-type: none"> 1.3H : 130 mm (Only with "VF105S" & "VF110") 1.45H : 145 mm (Only with "VF130") 1.55H : 155 mm (Only with "VF130S") 1.75H : 175 mm (Only with "VF110") 2H30H : 200 to 3000 mm (Only with "VF110", "VF130" & "VF185: Flange version") 2H : 200 mm (Only with "VF185") 2.5H30H : 250 to 3000 mm (Only with "185" & "Screwed Mounting")

Example -

VITAL-I-SCUTE-PCPG13-ASi-3-NS-MB15S4-VF185-HB-10T-2H